

CRANE Series



CRN Series - LDR/ LDF

Overview:

CRN-LDR/LDF is IP65 Protected Rigid Aluminium Die Cast Construction Crane Scale, Anti-dust, splash proof and anti magnetic, Ideal for use in manufacturing setups, factories, Steel Industries and heavy duty industrial plants with alloy steel die pressed bow shackle. 360 ° rotating (*LDF comes with a fixed hook) alloy steel die pressed lifting hook with safety latch. Equipped with infrared wireless remote control for simple user friendly operation and external battery charger and 2 sets of battery for 24 x 7 use.

Features:

- Weight Accumulation Function.
- Simple User Friendly Operation.
- Colour coded & sealed keypad
- Over Discharge protection circuit
- Rigid Aluminium Die cast housing - IP65
- Sealed High Precision S-Type Load Cell - IP67
- Built in Battery backup for 8 hrs operation.
- 2nd Battery provided with external charger to keep your scale running 24 x 7.
- Auto Sleep/Power Down Function - Saves Battery.

Technical Specifications:

- Time to Stabilize - 6s-9s
- Operating Temperature -0°C - 45°C
- Battery Capacity - 6V/4.5 AH
- 5 Digital 40mm High Visibility LED Display
- Overload - 100% Full Scale + 9e
- Safeload - 150% of Full Scale
- Break Point - 300% of Full Scale
- Infrared wireless remote control - distance 0 to 5 mtrs, clear line of sight.



Range:

Model	Capacity	Readability	Bottom Hook	Stamping Class
CRN-LDR	1000 kg	500 g	Rotating - Alloy Steel	Class III
CRN-LDR	2000 kg	1 kg	Rotating - Alloy Steel	Class III
CRN-LDR	3000 kg	1 kg	Rotating - Alloy Steel	Class III
CRN-LDR	5000 kg	2 kg	Rotating - Alloy Steel	Class III
CRN-LDR	10000 kg	5 kg	Rotating - Alloy Steel	Class III
CRN-LDF	15000 kg	10 kg	Fixed - Alloy Steel	Class III

Dimensions:

Model	Cap(t)	A	B	E	G	H	L	L1	ØD1	ØD2	ØD3	Wt kg
CRN-LDR	1	42	120	90	163	198	420	33	47	76	24	9
CRN-LDR	2	42	120	90	163	198	420	33	47	76	24	9
CRN-LDR	3	45	120	90	163	198	462	40	50	76	24	9
CRN-LDR	5	50	120	105	163	198	511	50	52	80	26	14
CRN-LDR	10	52	135	130	181	206	589	62	52	90	36	24
CRN-LDR	20	60	135	142	181	206	727	77	60	135	47	46

Note: All Dimensions are in 'mm'

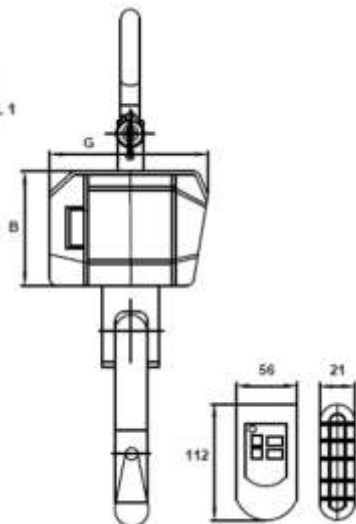
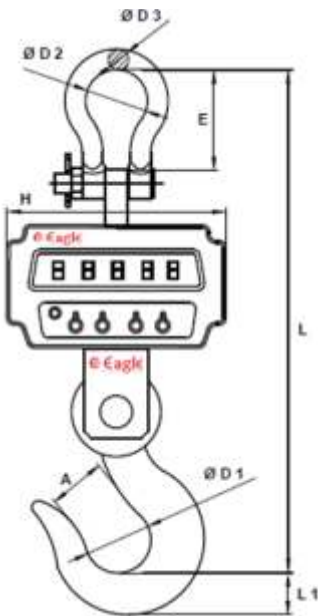

Accessories:

Infrared Wireless Remote Control



Infrared wireless remote control to easily operate the scale from below distance 0 to 5 mtrs, clear line of sight.

CRN Series - HDF

Overview:

CRN – HDF is a solid steel construction for long term durability for heavy duty use with anti-dust , splashproof and anti magnetic, Ideal for use in Rough Industrial Environment on account of its solid steel structure. Convenient and Safe to use. High Grade Alloy Steel Load cell ensures high accuracy. Equipped with infrared wireless remote control for simple user friendly operation and external battery charger and 2 sets of battery for 24x7 use.

Features:

- Weight Accumulation Function
- Simple User Friendly Operation
- Push Button Industrial Switches
- Over Discharge Protection Circuit
- Specialized Pull Force Load Cell For Long Life & High Accuracy
- Solid Steel Construction For Long Term Durability
- Dust Proof - IP 54
- Built-In Battery Backup for 8 Hours Operation
- 2nd Battery provide with external charger to keep your scale running 24 x 7.
- Auto Sleep / Power Down Function – Saves Battery

Technical Specifications:

- Time To Stabilize - 6s ~ 9s
- Operating Temperature - 0°C ~ 45°C
- Battery Capacity - 6V/4.5 AH
- 5 Digit 40mm High Visibility LED Display
- Overload -100% Full Scale +9e
- Safeload - 150% of Full Scale
- Break Point - 300% of Full Scale
- Infrared wireless remote control - distance 0 to 5 mtrs, clear line of sight.



Range:

Model	Capacity	Readability	Bottom Hook	Stamping Class
CRN - HDF	20000 kg	10 kg	Fixed - Alloy Steel	Class II
CRN - HDF	30000 kg	10 kg	Fixed - Alloy Steel	Class II
CRN - HDF	40000 kg	20 kg	Fixed - Alloy Steel	Class II
CRN - HDF	50000 kg	20 kg	Fixed - Alloy Steel	Class II

Dimensions:

Model	Cap(t)	A	B	E	G	H	L	L1	ØD1	ØD2	ØD3	Wt kg
CRN-HDF	20	73	158	219	206	230	811	76	90	150	51	77
CRN-HDF	30	120	159	279	212	236	992	120	130	150	65	127
CRN-HDF	40	130	215	313	300	300	1213	140	150	214	72	230
CRN-HDF	50	130	215	313	300	300	1213	140	150	214	72	230

Note: All Dimensions are in 'mm'

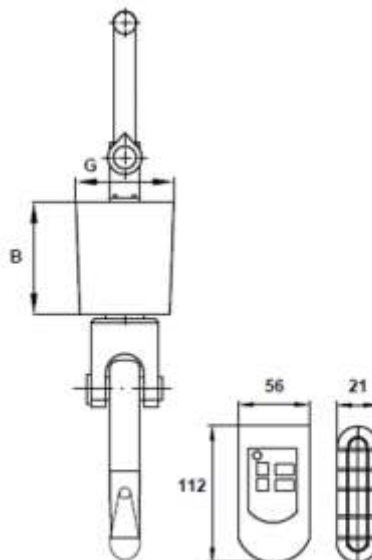
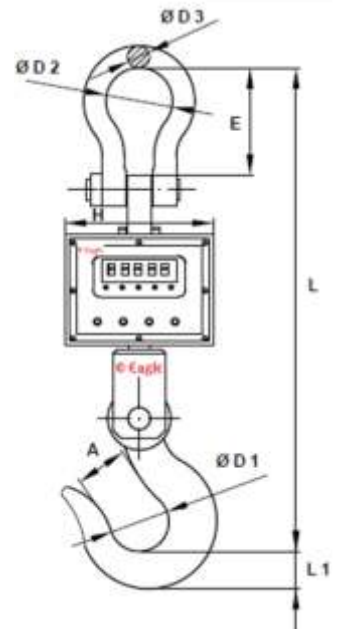

External Battery Charger



Fully Drained battery - will get fully charged in 8 hours.

E. G. KANTAWALLA PVT. LTD.

www.eaglescales.in

www.egkantawalla.com

Additional options



Wireless Scoreboard

Features:

100mm LED Display Size 200m
Distance Of Operation (Clear Line
Of Sight)



Handheld Wireless Indicator

Features:

LCD Display DOT-Matrix Printer,
RS-232, Built-in RTC, Prints -
time, date, 4 Digit Item Code &
Weight.

Printout Format

Accumulation Weighing Slip

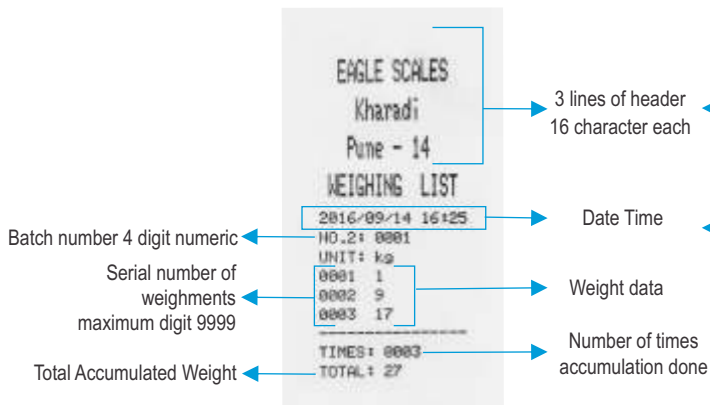

Single Weighment Slip

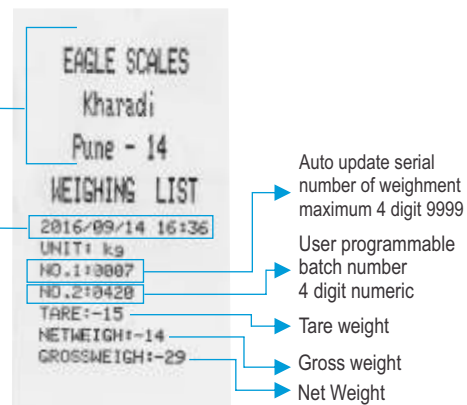

Model Approval No.:
IND/09/10/121



*Models and specification are subject to change without any prior notification.
*For non standard equipment consult factory