

INDIA'S NO.1 QUALITY ELECTRONIC WEIGHING SCALES

# Crane Scale



An ISO:9001-2000 Certified Company

Caston Series

THB



- Easy-to-Read 1.2" Led Display
- Wireless Remote Control Standard
- Battery Operated

**Upto 5 Ton**

**CAS**

THZ



- Wireless Remote Provides easy & convenient operation from a distance
- Light and concrete aluminum case supplies hard-wearing
- LED Display provides high visibility from a distance
- It is convenient to use and move the scale by rechargeable battery.



## FEATURES

- Battery Operated with Low Battery Indication
- Rechargeable Battery Pack
- Spare Battery Pack and Charger Included as Standard
- Remote Control Included as Standard
- On, Off, Zero, Tare, and Hold (Manual or Automatic) Functions
- Easy-to-Read 1.2" LED Display
- Auto Span Adjustment
- Auto Zero Tracking

## SPECIFICATIONS

Model	0.5 THB	1 THB	2 THB	3 THB	5 THB
Weighing Capacity	500x0.2kg	1000x0.5kg	2000x1kg	3000x2kg	5000x2kg
Maximum Tare	Full Tare				
Display Type	LED (1.2 inch)				
Operating Power	DC 6V				
Power Source	AC 110/120/220/24v, 50/60 Hz				
Display Designators	Zero, Tare, Hold, Batt.				
Power Consumption	1W				
Operating Temperature	-10°C~+40°C				
Product Weight	15 kg		17 kg		20 kg



▲ Display & Key Board



▶ Battery Pack Installation

## FEATURES

- Easy-to-read 38mm LED Display
- Aluminum die-casting enclosure
- High capacity rechargeable battery

## SPECIFICATIONS

Model	CASTON (THZ) Series					
Weighing Capacity	1,000	2,000	3,000	5,000	10,000	20,000
Maximum Tare	0.5	1	1	1	2	10
Display Type	1/2,000	1/2,000	1/3,000	1/2,500	1/2,500	1/2,000
Operating Power	ON/OFF, ZERO, TARE, HOLD					
Power Source	Auto off set, Low voltage alarm, Resolution Switch					
Display Designators	1.5 inch (38.1) ultra-luminance LED					
Power Consumption	6V/100AH (PB BATTERY)					
Operating Temperature	230(W) X 350(D) X 420(H) - 2 TON, 230(W) X 350(D) X 585(H) - 5 TON, 230(W) X 350(D) X 770(H) - 10 TON, 230(W) X 350(D) X 950(H) - 20 TON					
Product Weight	16.2 ton, 25.5 ton, 47.10 ton, 68.20 ton					

## DIMENSIONS

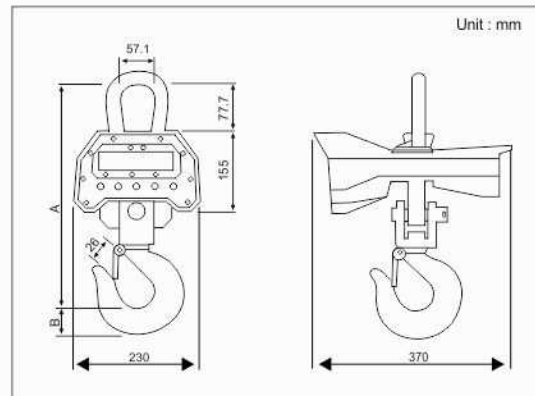

**CAS WEIGHING INDIA Pvt. Ltd.**

### Factory & Corporate Office :

788, Udyog Vihar, Phase-V, Gurgaon-122016

Tel. : (0124) 2342621/3/4, 4011651/2/3

Fax : (0124) 2342626 E-mail : sales@casindia.in, service@casindia.in

### Mumbai Branch Office :

508, D Wing, 3rd Floor, Vashi Plaza, Sector-17, Vashi, New Mumbai-400703

Ph. : (022) 67911551 Telefax : 67911550

**CAS**

CAS BLDG., # 440-1, SUNGNAE-DONG,

GANGDONG - GU, SEOUL, KOREA

TEL : 82-2-2225-3500

FAX : 82-2-475-4668

http://www.cas.co.kr

## CAS Authorised Sale & Service Centres

Abohar	Bangalore	Chitgaon	Ernakulam	Jamshedpur	Kollam	Murshidabad	Pune	Tiripur
Alwar	Bankura	Cochin	Faridabad	Jhajjar	Kota	Muzaffarnagar	Pondicherry	Tonk
Agra	Balasore	Coimbatore	Gaya	Jind	Kotdwar	Mysore	Raipur	Trichi
Ahmedabad	Baroda	Darjeeling	Guwahati	Jodhpur	Kutch	Muzzaffarpur	Rajamundhary	Trissur
Ambala	Batala	Dehradun	Ghaziabad	Junagarh	Kotayam	Nagaland	Ranchi	Thiruvallu
Ambedkar Nagar	Berhampur	Delhi	Goa	Kangra	Kutchnow	Nayagarh	Rajkot	Trivandrum
Amroha	Bhagalpur	Delhi West	Gorakhpur	Kannur	Ludhiana	Nagpur	Rohtak	Tumkur
Angul	Bhatinda	Delhi North & Central	Gwalior	Kanpur	Mallapuram	Nimuch	Rourkela	Udaipur
Ankleshwar	Bhopal	Delhi East	Haridwar	Karur	Madurai	Palakkad	Rudrapur	Varanasi
Allappay	Bhilwara	Delhi South	Hoogly	Kargil	Mangalore	Palampur	Sumerpur	Vijaywada
Adilabad	Bijner	Dimapur	Hyderabad	Katihar	Mehsana	Panipat	Shimla	Villupuram
Assam	Burdwan	Davanagere	Indore	Kolkata	Meerut	Parwanoo	Srinagar	Virudhnagar
Asansol	Calicut	Dhanbad	Jaipur	Kolkata South	Midnapore	Palamu	Silliguri	Vishakapatnam
Aurangabad	Cuttack	Durg	Jaisalpur	Kolkata North	Moradabad	Patiala	Sundarnagar	Visnagar
Bahadurgarh	Chandigarh	Durgapur	Jammu	Kolkata Stand Rd.	Mumbai	Patna	Surat	Wayanad
	Chennai	Erode	Jamnagar				Tanda	Yamuna Nagar

Specifications subject to change for improvement without prior notice.

Complies with Rules & Regulations of Dept. of Legal Metrology, Govt of India.