

DS-315

Crane Weigher

Essae[®]
...for Excellence



Lift your productivity and profits to a new high

- Large and Bright LED display (30 mm)
- Long battery backup
- Remote control and display for easy operation
- Ideal for foundries / ladle weighment

Technical Specifications

Power supply	230 V AC, 50 Hz.
Power consumption	6 W
Display	LED (RED)
Display digit	5 Digits
Display size	30 mm
Number of keys	3 Keys
Battery charger	External
Battery	In-built 6 V / 7 Ah Rechargeable battery
Remote control	Key operation
Battery operation	40 Hours (When battery is fully charged)

Options:

- Wireless Remote Display
- Thermal Crane Scale
- Wireless Remote Indicator with Printer

Cap / Accu	1 Ton / 500g	3 Ton / 1 kg	5 Ton / 2 kg	10 Ton / 5 kg	15 Ton / 5 kg	20 Ton / 10 kg	30 Ton / 10 kg
Hook size	201	201	256	316	450	450	560
H	422	477	572	672	985	985	1075
H1	100	100	115	137	255	255	285
K	27	31	48	57	90	90	102
D1	64	64	74	88	139	139	165
D2	36	50	60	70	120	120	120
Thickness of top hook	21	21	27	34	47	47	59
Weight	14	15	21	34	86	86	146

Note: All Dimensions in mm

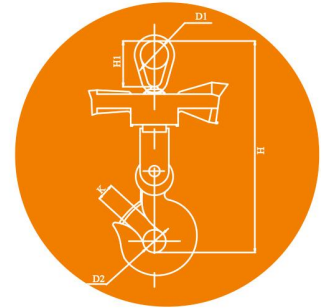

Wireless Remote Indicator with Printer (Option)



Thermal Scale with cover



Wireless Remote Display (Option)