

# CRN Series - LDR/ LDF

### Overview:

CRN-LDR/LDF is IP65 Protected Rigid Aluminium Die Cast Construction Crane Scale, Anti-dust, splash proof and anti magnetic, Ideal for use in manufacturing setups, factories, Steel Industries and heavy duty industrial plants with alloy steel die pressed bow shackle. 360 ° rotating (\*LDF comes with a fixed hook) alloy steel die pressed lifting hook with safety latch. Equipped with infrared wireless remote control for simple user friendly operation and external battery charger and 2 sets of battery for 24 x 7 use.

### Features:

- Weight Accumulation Function.
- Simple User Friendly Operation.
- Colour coded & sealed keypad
- Over Discharge protection circuit
- Rigid Aluminium Die cast housing - IP65
- Sealed High Precision S-Type Load Cell - IP67
- Built in Battery backup for 8 hrs operation.
- 2nd Battery provided with external charger to keep your scale running 24 x 7.
- Auto Sleep/Power Down Function - Saves Battery.

### Technical Specifications:

- Time to Stabilize - 6s-9s
- Operating Temperature -0°C - 45°C
- Battery Capacity - 6V/4.5 AH
- 5 Digital 40mm High Visibility LED Display
- Overload - 100% Full Scale + 9e
- Safeload - 150% of Full Scale
- Break Point - 300% of Full Scale
- Infrared wireless remote control - distance 0 to 5 mtrs, clear line of sight.



### Range:

Model	Capacity	Readability	Bottom Hook	Stamping Class
CRN-LDR	1000 kg	500 g	Rotating - Alloy Steel	Class III
CRN-LDR	2000 kg	1 kg	Rotating - Alloy Steel	Class III
CRN-LDR	3000 kg	1 kg	Rotating - Alloy Steel	Class III
CRN-LDR	5000 kg	2 kg	Rotating - Alloy Steel	Class III
CRN-LDR	10000 kg	5 kg	Rotating - Alloy Steel	Class III
CRN-LDF	15000 kg	10 kg	Fixed - Alloy Steel	Class III

### Dimensions:

Model	Cap(t)	A	B	E	G	H	L	L1	ØD1	ØD2	ØD3	Wt kg
CRN-LDR	1	42	120	90	163	198	420	33	47	76	24	9
CRN-LDR	2	42	120	90	163	198	420	33	47	76	24	9
CRN-LDR	3	45	120	90	163	198	462	40	50	76	24	9
CRN-LDR	5	50	120	105	163	198	511	50	52	80	26	14
CRN-LDR	10	52	135	130	181	206	589	62	52	90	36	24
CRN-LDR	20	60	135	142	181	206	727	77	60	135	47	46

Note: All Dimensions are in 'mm'

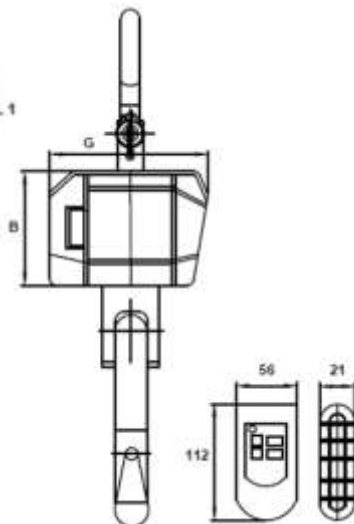
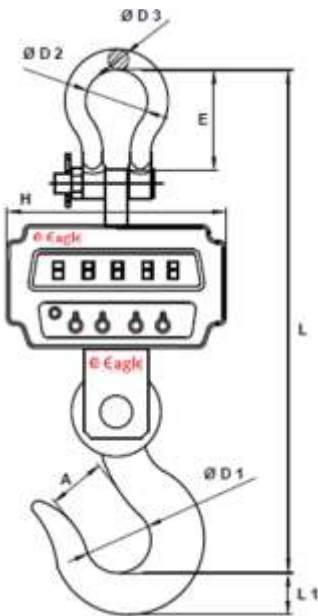

### Accessories:

#### Infrared Wireless Remote Control



Infrared wireless remote control to easily operate the scale from below distance 0 to 5 mtrs, clear line of sight.

E. G. KANTAWALLA PVT. LTD.

www.eaglescales.in

www.egkantawalla.com

## Additional options



Wireless Scoreboard

### Features:

100mm LED Display Size 200m  
Distance Of Operation ( Clear Line  
Of Sight)



Handheld Wireless Indicator

### Features:

LCD Display DOT-Matrix Printer,  
RS-232, Built-in RTC, Prints -  
time, date, 4 Digit Item Code &  
Weight.

## Printout Format

### Accumulation Weighing Slip

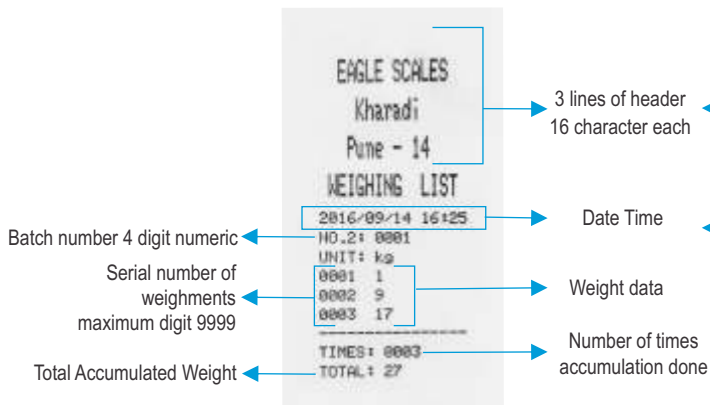

### Single Weighment Slip

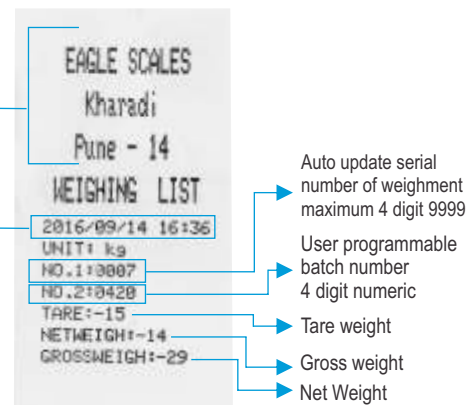

Model Approval No.:  
IND/09/10/121



\*Models and specification are subject to change without any prior notification.  
\*For non standard equipment consult factory